

SHOP No.6  
First Floor

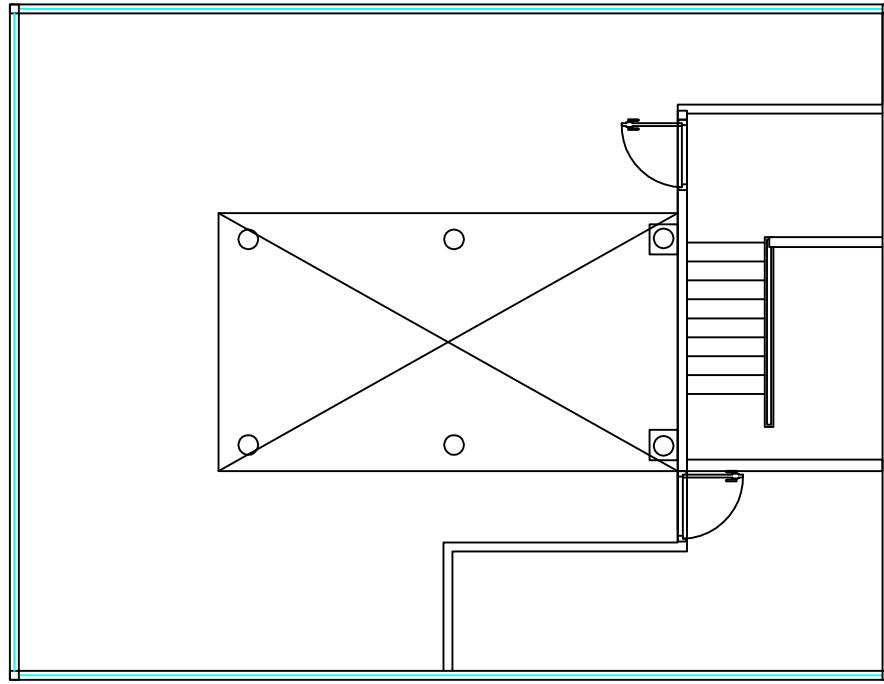

# The Courtyard, Montpellier Street, Cheltenham

## EXISTING SHOP LAYOUT

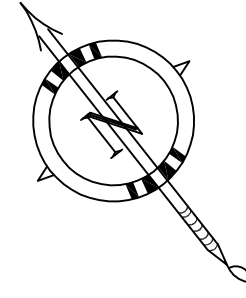

Michael Thomas House  
East Road  
Oundle  
Peterborough  
PE8 4BZ  
t. 01832 270 501 f. 01832 275 730  
info@OptimumDesignServices.co.uk  
www.optimumdesignservices.co.uk



Chartered Surveyors  
212 Piccadilly  
London  
W1J 9HJ  
t. 0207 993 6774 tm@mpam.co.uk

SITE The Courtyard, Montpellier Street, Cheltenham		
DETAILS PROPOSED SHOP 6 LAYOUT		
SCALE: 1/100@A3	DRAWING NO. The Courtyard-CP1	REVISION A
DRAWN J Walker	CHECKED	DATE March 2011

Ground Floor

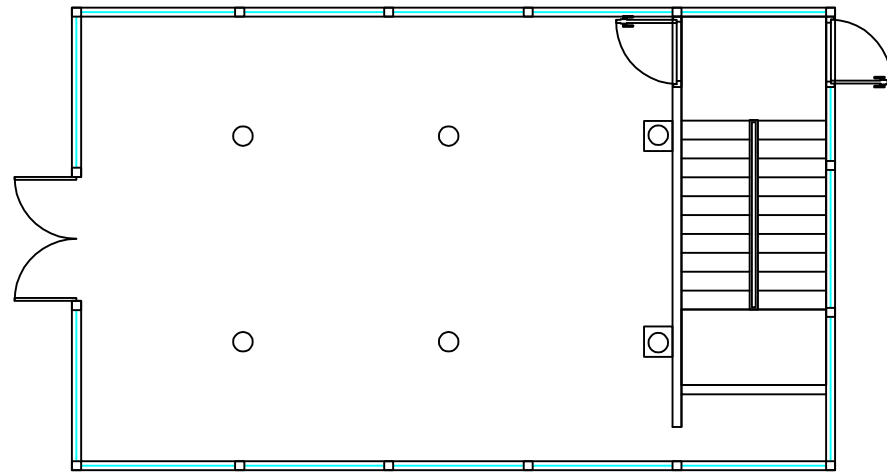

Basement

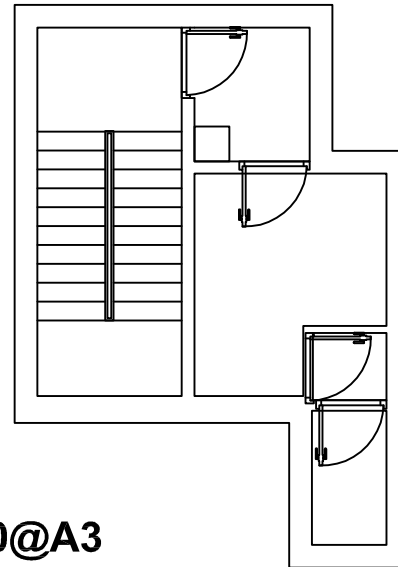

SCALED 1/100@A3

Ordnance Survey<sup>®</sup>  
OS Sitemap<sup>™</sup>

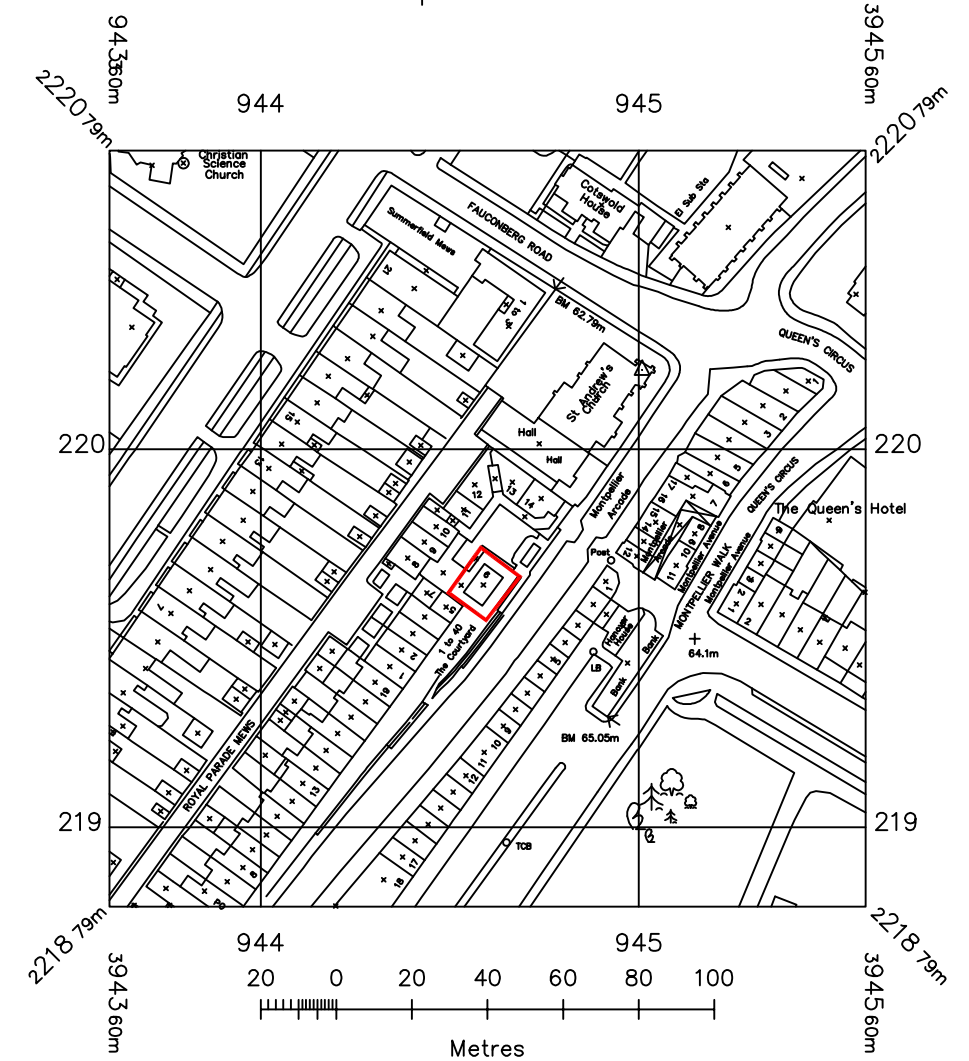

© Crown Copyright 2011

Reproduction in whole or in part is prohibited  
without the prior permission of Ordnance Survey.

SCALED 1/2000@A3

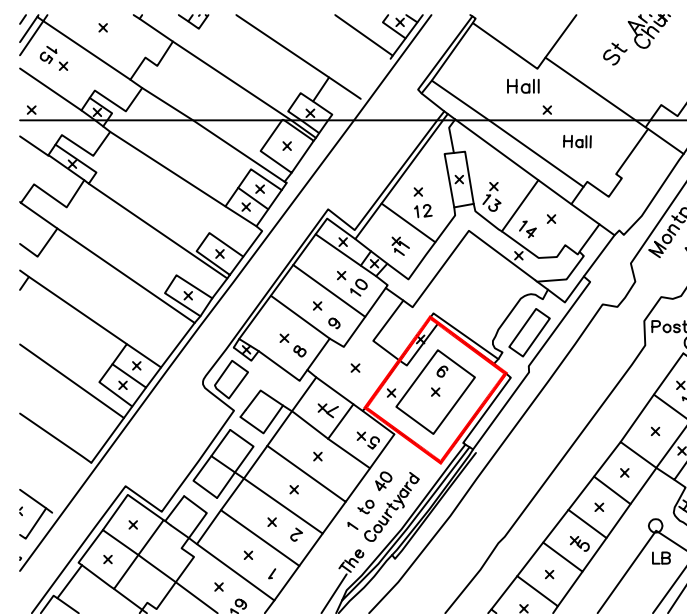

SCALED 1/1000@A3